

LIFTING CARE AND SAFETY TO NEW HEIGHTS



INTRODUCING OUR NEW LINE
OF ALLIANCE[™] PATIENT LIFTS



Chattanooga Alliance Safe Patient Handling and Mobility products provide a value-based solution to improve patient's quality of life by reducing complications of patient immobility and falls, while reducing costs associated with injuries to caregivers.



REDUCE COMPLICATIONS OF IMMOBILITY

- Cardiovascular: deep vein thrombosis (DVT), hypotension
- Gastrointestinal: constipation
- Musculoskeletal: deconditioning, bone demineralization, joint contractures
- Genitourinary: urinary infection, incontinence
- Skin: pressure ulcers (bedsores)
- Psychosocial: depression, decreased functional capacity, increased dependency

REDUCE INJURIES TO CAREGIVERS

- Reduced costs from workers compensation and lost or restricted work days
- Improved worker retention and reduced turnover costs

REDUCE PATIENT FALLS

- 24% of the population between the ages of 65 and 75 report one or more falls in a year
- Up to 70% of falls result in injuries
- Falls are the most common cause of injury in old age

SOLUTIONS ACROSS ALL LEVELS OF ACUITY

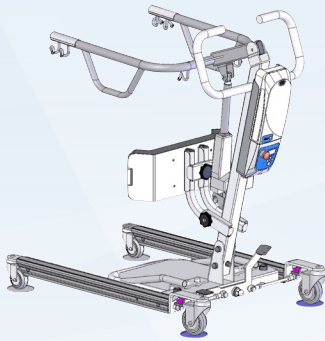

STAND-ASSIST

Available in 400, 500 and 600 weight capacity

Helps patients who lack the strength or muscle control to rise to a standing position by using battery power

Transfers are made from seated to seated positions (Wheelchair, Toilet, Chair, Bed)

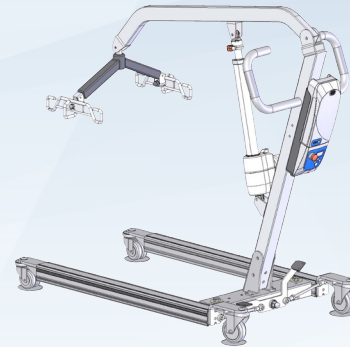

FULL BODY PATIENT LIFTS

Available in 400, 500 and 600 weight capacity

These devices enable the caregiver to lift patients whose mobility is very limited by using battery or hydraulic power

Transfers are made from lying to seated positions and seated to lying positions (Floor, Bed, Toilet, Chair, Wheelchair)

Performance Electronics

- Detachable battery pack
- Dual independent battery gauge
- LCD display
- Internal charger
- Backup controls on the control box
- Compatible with Chattanooga Alliance Performance or Legacy actuators

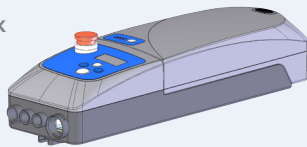

Dual battery continuous operation on Performance models with wall mount and charger

- Includes Performance control box and electronics and external charging station
- Two battery packs for continuous availability

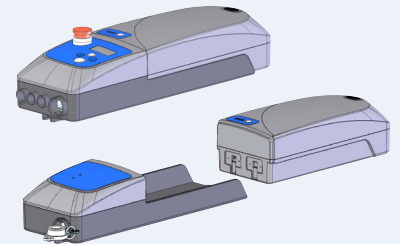

STAND-AID

Positioned between traditional walkers or wheelchair

The Alliance Stand Aid is a transport assist unit which keeps residents active and engaged in the lifting process. Transport is quick and requires minimal caregiver assistance. This versatile device can be used for weight bearing exercises within a fall prevention environment



TRANSFER AIDS

Positioning aids (soft goods) that include things like gait belts and repositioning products

Gait belt devices help to manually transfer residents who have some weight-bearing capacity

EXTENSIVE OFFERING OF OVER 18 SLING STYLES

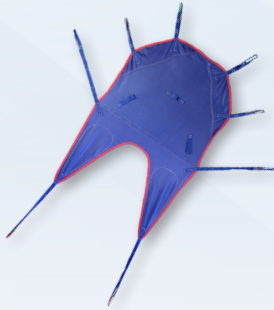

UNIVERSAL SLING

Universal slings or “U” slings allow for easier application than full body slings. Available in mesh or full deluxe padded styles. Also available with full head support.



SANI-SLING

Toileting sling made for maximum functionality and patient dignity. Eliminates need for poorly designed commode opening slings. Alliance Sani slings also work extremely well on Stand assist lifts.



STANDASSIST

Lumbar and underarm pads provide maximum comfort for the patient. Optional buttock strap attachment is available and a calf strap is also available for stabilization support.

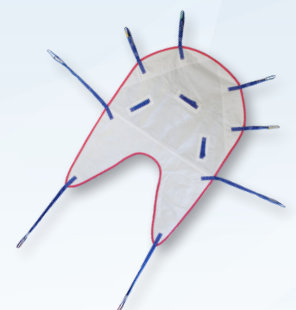

SINGLE PATIENT SPECIFIC (SPS)

Alliance Single Patient Specific slings are made from a polypropylene non woven layered fabric. Cost effective method of controlling cross contamination and an excellent alternative to laundering costly cloth slings. Each sling has a spot to mark the name of the specific patient and date issued. Latex free and tested at 1.5 times the safe working load.



DJO, LLC | A DJO Global Company

T 800.592.7329 **D** 760.727.1280 **F** 800.936.6569

1430 Decision Street | Vista, CA 92081-8553 | U.S.A.

DJOglobal.com/chattanooga

Together in Motion™

* Robert L. Kane et al. Essentials of Clinical Geriatrics, 5th ed. New York: McGraw-Hill (2004), 245-48; and Rosemary A. Timmerman, "A mobility protocol for critically ill adults," *Dimensions of Critical Care Nursing* 26, no. 5 (Sept.-Oct. 2007):175-79.

- Chang JT, Morton SC, Rubenstein LZ, Mojica WA, Maglione M, Suttrop MJ, Roth EA, Shekelle PG. Interventions for the prevention of falls in older adults: systematic review and meta-analysis of randomised clinical trials. *BMJ* 2004;328(7441):680.
- Guilbert P, Gautier A. Baromètre Santé 2005: Premiers Résultats. Paris, France: Institut National de Prévention et d'Éducation Pour la Santé; 2006
- Grenier-Sennelier C, Lombard I, Jeny-Loeper C, Maillet-Gouret M, Minvielle E. Designing adverse event prevention programs using quality management methods: the case of falls in hospital. *Int J Qual Health Care* 2002;14:419-26.
- E. Nordin, N. Lindelof, E. Rosendahl, J. Jensen, and L. Lundin-olsson. Prognostic validity of the Timed Up-and-Go test, a modified Get-Up-and-Go test, staff's global judgement and fall history in evaluating fall risk in residential care facilities *Age and Ageing*, July 1, 2008; 37(4): 442 - 448

- Leveille SG, Jones RN, Kiely DK, Hausdorff JM, Shmerling RH, Guralnik JM, Kiel DP, Lipsitz LA, Bean JF. Chronic musculoskeletal pain and the occurrence of falls in an older population. *JAMA*. 2009 Nov 25;302(20):2214-21.
- Ref *Garg, Arun. "Long-term Effectiveness of "Zero-lift Program" in Seven Nursing Homes and One Hospital." *National Institute for Occupational Safety and Health*. 1999
- Ref *Siddharthan, Kris, Audrey Nelson, Gregory Weisenborn, "A business case for patient care ergonomic interventions," *Nursing Administration Quarterly*, January March, 2005, 29(1).
- Nurs Adm Q. 2005 Jan-Mar;29(1):63-71. A business case for patient care ergonomic interventions. Siddharthan K, Nelson A, Weisenborn G. Source: Patient Safety Center of Inquiry, James A. Haley Veterans Administration Medical Center, Tampa, FL 33612, USA. kris.siddharthan@med.va.gov
- Garg A, Owen B. Reducing back stress to nursing personnel: an ergonomic intervention in a nursing home. *Ergonomics* 1992;35:1353-75. U.S. Department of Labor, Occupational Safety and Health Administration. (2002). *Ergonomics guidelines for nursing homes*. Retrieved June 22, 2003